



**SHELVES**

**PREMIER LINE – All 304 S/S Construction**

Wall Shelf . . . . .	2
Table Mounted Shelf, Single. . . . .	3
Table Mounted Shelf, Double . . . . .	4
Pass Thru Shelves . . . . .	5
Wall Shelf / Pot Rack Combo . . . . .	6
Wall Mounted Pot Rack, Single . . . . .	7
Wall Mounted Pot Rack, Double . . . . .	8
Table Mounted Pot Rack, Single . . . . .	9
Table Mounted Pot Rack, Double . . . . .	10
Ceiling Mounted Pot Rack . . . . .	11

**STANDARD LINE – S/S Construction**

Wall Shelf . . . . .	12
Table Mounted Shelf, Single. . . . .	13
Table Mounted Shelf, Double . . . . .	14
Wall Shelf / Pot Rack Combo . . . . .	15
Microwave Shelves . . . . .	16
Slant Wall Shelf . . . . .	17
Double Rack Shelf . . . . .	18

# Premier Line Wall Shelves

## WSP-Wall Shelves

Item #: \_\_\_\_\_ Qty #: \_\_\_\_\_

Model #: \_\_\_\_\_

Project: \_\_\_\_\_

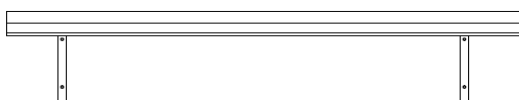
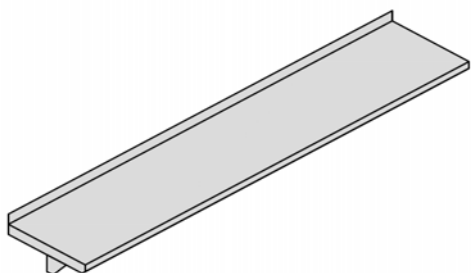

Note: Shelves in excess of 84" will receive 3 brackets

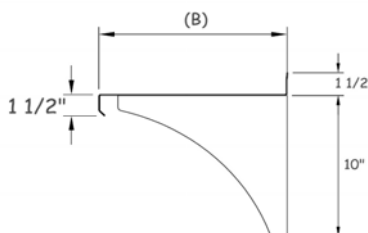
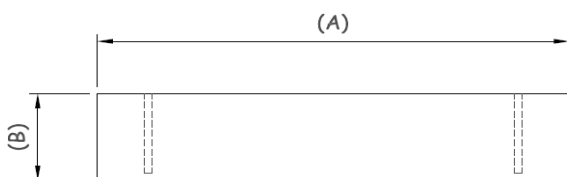

### Features:

- Furnished with a 1 1/2" turn up at rear with 1 1/2" turn down front and sides
- Easy installation that includes 1 bracket every 36"

### Construction:

- All shelves are fully welded and polished to a smooth grain finish
- "304" stainless steel.
- Brackets are shipped loose



### Options:

- Left end turn up
- Right end turn up
- 16 ga. Shelf / 14 ga. Brkts.
- Other \_\_\_\_\_

### Material:

**Shelf:** 18 gauge type "304" series stainless steel

**Brackets:** 16 gauge stainless steel

### Custom Sizes Available!

MODEL NUMBER	QTY	DIMENSIONS		WT. (lbs.)	MODEL NUMBER	QTY	DIMENSIONS		WT. (lbs.)	MODEL NUMBER	QTY	DIMENSIONS		WT. (lbs.)
		A	B				A	B				A	B	
WSP-36-12		36"	12"	15	WSP-72-14		72"	14"	35	WSP-108-16		108"	16"	60
WSP-36-14		36"	14"	18	WSP-72-16		72"	16"	40	WSP-108-18		108"	18"	68
WSP-36-16		36"	16"	20	WSP-72-18		72"	18"	45	WSP-120-12		120"	12"	50
WSP-36-18		36"	18"	23	WSP-84-12		84"	12"	35	WSP-120-14		120"	14"	59
WSP-48-12		48"	12"	20	WSP-84-14		84"	14"	41	WSP-120-16		120"	16"	67
WSP-48-14		48"	14"	23	WSP-84-16		84"	16"	47	WSP-120-18		120"	18"	75
WSP-48-16		48"	16"	27	WSP-84-18		84"	18"	53	WSP-132-12		132"	12"	55
WSP-48-18		48"	18"	30	WSP-96-12		96"	12"	40	WSP-132-14		132"	14"	64
WSP-60-12		60"	12"	25	WSP-96-14		96"	14"	47	WSP-132-16		132"	16"	73
WSP-60-14		60"	14"	29	WSP-96-16		96"	16"	53	WSP-132-18		132"	18"	83
WSP-60-16		60"	16"	33	WSP-96-18		96"	18"	60	WSP-144-12		144"	12"	60
WSP-60-18		60"	18"	38	WSP-108-12		108"	12"	45	WSP-144-14		144"	14"	70
WSP-72-12		72"	12"	30	WSP-108-14		108"	14"	53	WSP-144-16		144"	16"	80
<b>CUSTOM SHELF</b>		<b>DIM. A</b>		<b>DIM. B</b>	<b>QTY</b>	WSP-144-18		144'	18"	90				

WT. = Crated shipping weight

[www.weststarindustries.com](http://www.weststarindustries.com)

4445 E. Fremont Street / Stockton, CA 95215

Phone: 800-326-2288 Fax: (209) 955-8250 CL# 422322

Email: [wsj@weststarindustries.com](mailto:wsj@weststarindustries.com)

Note: Specifications are subject to change without notice.

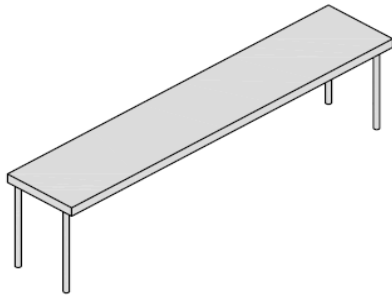

Item #: \_\_\_\_\_ Qty #: \_\_\_\_\_

Model #: \_\_\_\_\_

Project: \_\_\_\_\_

**Features:**

- Furnished with 1" turn down on four sides.
- All shelves are fully welded and polished to a smooth grain finish.

**Construction:**

- 1" stainless steel legs
- "304" stainless steel
- Galvanized support channels

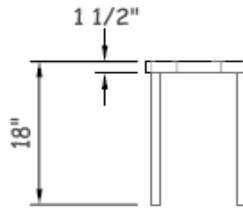
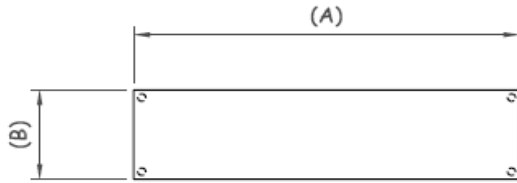

Models over 84" will receive 3 sets of legs

**Options:**

- 1 5/8" round legs
- 1" turn up rear
- 1" turn up left
- 1" turn up right
- Mounting brackets for existing table
- Heat lamp brackets
- Rolled edges on long sides
- Hi-lited edges
- Mounting location: *(circle below)*  

Front
Center
Rear
- Electrical boxes QTY \_\_\_\_\_
- Other: \_\_\_\_\_

**Material:**

**Shelf:** 18 gauge stainless steel

**Legs:** 1" round stainless steel

**Custom Sizes Available!**

MODEL NUMBER	DIMENSIONS		WT. (lbs.)	MODEL NUMBER	DIMENSIONS		WT. (lbs.)	MODEL NUMBER	DIMENSIONS		WT. (lbs.)	MODEL NUMBER	DIMENSIONS		WT. (lbs.)
	A	B			A	B			A	B			A	B	
TSP-1-36-10	36"	10"	13	TSP-1-60-16	60"	16"	34	TSP-1-96-10	96"	10"	34	TSP-1-120-16	120"	16"	67
TSP-1-36-12	36"	12"	15	TSP-1-60-18	60"	18"	38	TSP-1-96-12	96"	12"	40	TSP-1-120-18	120"	18"	75
TSP-1-36-14	36"	14"	18	TSP-1-60-20	60"	20"	42	TSP-1-96-14	96"	14"	47	TSP-1-120-20	120"	20"	84
TSP-1-36-16	36"	16"	20	TSP-1-72-10	72"	10"	25	TSP-1-96-16	96"	16"	54	TSP-1-132-10	132"	10"	46
TSP-1-36-18	36"	18"	23	TSP-1-72-12	72"	12"	30	TSP-1-96-18	96"	18"	60	TSP-1-132-12	132"	12"	55
TSP-1-36-20	36"	20"	25	TSP-1-72-14	72"	14"	35	TSP-1-96-20	96"	20"	67	TSP-1-132-14	132"	14"	65
TSP-1-48-10	48"	10"	16	TSP-1-72-16	72"	16"	40	TSP-1-108-10	108"	10"	38	TSP-1-132-16	132"	16"	73
TSP-1-48-12	48"	12"	20	TSP-1-72-18	72"	18"	45	TSP-1-108-12	108"	12"	45	TSP-1-132-18	132"	18"	83
TSP-1-48-14	48"	14"	24	TSP-1-72-20	72"	20"	50	TSP-1-108-14	108"	14"	53	TSP-1-132-20	132"	20"	92
TSP-1-48-16	48"	16"	27	TSP-1-84-10	84"	10"	30	TSP-1-108-16	108"	16"	60	TSP-1-144-10	144"	10"	50
TSP-1-48-18	48"	18"	30	TSP-1-84-12	84"	12"	35	TSP-1-108-18	108"	18"	68	TSP-1-144-12	144"	12"	60
TSP-1-48-20	48"	20"	34	TSP-1-84-14	84"	14"	41	TSP-1-108-20	108"	20"	75	TSP-1-144-14	144"	14"	70
TSP-1-60-10	60"	10"	21	TSP-1-84-16	84"	16"	47	TSP-1-120-10	120"	10"	42	TSP-1-144-16	144"	16"	80
TSP-1-60-12	60"	12"	25	TSP-1-84-18	84"	18"	53	TSP-1-120-12	120"	12"	50	TSP-1-144-18	144"	18"	90
TSP-1-60-14	60"	14"	29	TSP-1-84-20	84"	20"	59	TSP-1-120-14	120"	14"	58	TSP-1-144-20	144"	20"	100
								<b>CUSTOM</b>		<b>Dim. A</b>		<b>Dim. B</b>			

WT. = Crated shipping weight

[www.weststarindustries.com](http://www.weststarindustries.com)

4445 E. Fremont Street / Stockton, CA 95215

Phone: 800-326-2288 Fax: (209) 955-8250 CL# 422322

Email: [wsj@weststarindustries.com](mailto:wsj@weststarindustries.com)

Note: Specifications are subject to change without notice.

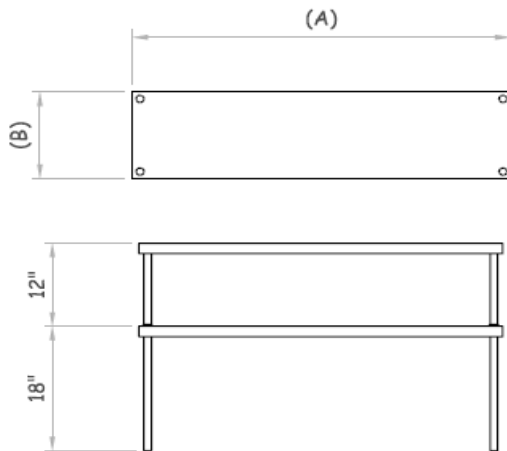
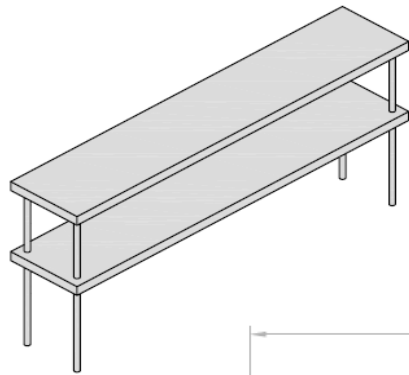

Item #: \_\_\_\_\_ Qty #: \_\_\_\_\_  
Model #: \_\_\_\_\_  
Project: \_\_\_\_\_

**Features:**

- Furnished with 1" turn down on four sides.
- All shelves are fully welded and polished to a smooth grain finish.

**Construction:**

- 1" stainless steel legs
- "304" stainless steel
- Galvanized support channels



**Options:**

- 1 5/8" round posts
  - 1" turn up rear
  - 1" turn up left
  - 1" turn up right
  - Mounting brackets for existing table
  - Heat lamp brackets
  - Rolled edges on long sides
  - Hi-lited edges
  - Mounting location: (circle below)
- Front    Center    Rear
- Electrical boxes    QTY \_\_\_\_\_
  - Other: \_\_\_\_\_

Models over 84" will receive 3 sets of legs

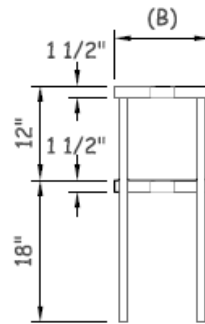

**Material:**

**Shelf:** 18 gauge stainless steel  
**Legs:** 1" round stainless steel

**Custom Sizes Available!**

MODEL NUMBER	DIMENSIONS		WT. (lbs.)	MODEL NUMBER	DIMENSIONS		WT. (lbs.)	MODEL NUMBER	DIMENSIONS		WT. (lbs.)	MODEL NUMBER	DIMENSIONS		WT. (lbs.)	
	A	B			A	B			A	B			A	B		
TSP-2-36-10	36"	10"	26	TSP-2-60-16	60"	16"	68	TSP-2-96-10	96"	10"	68	TSP-2-120-16	120"	16"	134	
TSP-2-36-12	36"	12"	30	TSP-2-60-18	60"	18"	76	TSP-2-96-12	96"	12"	80	TSP-2-120-18	120"	18"	150	
TSP-2-36-14	36"	14"	38	TSP-2-60-20	60"	20"	84	TSP-2-96-14	96"	14"	94	TSP-2-120-20	120"	20"	168	
TSP-2-36-16	36"	16"	40	TSP-2-72-10	72"	10"	50	TSP-2-96-16	96"	16"	108	TSP-2-132-10	132"	10"	92	
TSP-2-36-18	36"	18"	46	TSP-2-72-12	72"	12"	60	TSP-2-96-18	96"	18"	120	TSP-2-132-12	132"	12"	110	
TSP-2-36-20	36"	20"	50	TSP-2-72-14	72"	14"	70	TSP-2-96-20	96"	20"	134	TSP-2-132-14	132"	14"	130	
TSP-2-48-10	48"	10"	32	TSP-2-72-16	72"	16"	80	TSP-2-108-10	108"	10"	76	TSP-2-132-16	132"	16"	146	
TSP-2-48-12	48"	12"	40	TSP-2-72-18	72"	18"	90	TSP-2-108-12	108"	12"	90	TSP-2-132-18	132"	18"	166	
TSP-2-48-14	48"	14"	48	TSP-2-72-20	72"	20"	100	TSP-2-108-14	108"	14"	106	TSP-2-132-20	132"	20"	184	
TSP-2-48-16	48"	16"	54	TSP-2-84-10	84"	10"	60	TSP-2-108-16	108"	16"	120	TSP-2-144-10	144"	10"	100	
TSP-2-48-18	48"	18"	60	TSP-2-84-12	84"	12"	70	TSP-2-108-18	108"	18"	136	TSP-2-144-12	144"	12"	120	
TSP-2-48-20	48"	20"	68	TSP-2-84-14	84"	14"	82	TSP-2-108-20	108"	20"	150	TSP-2-144-14	144"	14"	140	
TSP-2-60-10	60"	10"	42	TSP-2-84-16	84"	16"	94	TSP-2-120-10	120"	10"	84	TSP-2-144-16	144"	16"	160	
TSP-2-60-12	60"	12"	50	TSP-2-84-18	84"	18"	106	TSP-2-120-12	120"	12"	100	TSP-2-144-18	144"	18"	180	
TSP-2-60-14	60"	14"	58	TSP-2-84-20	84"	20"	118	TSP-2-120-14	120"	14"	116	TSP-2-144-20	144"	20"	200	
									<b>CUSTOM</b>				<b>Dim. A</b>		<b>Dim. B</b>	

WT. = Crated shipping weight

# Premier Line

## Pass Thru Shelves

Item #: \_\_\_\_\_ Qty #: \_\_\_\_\_  
 Model #: \_\_\_\_\_  
 Project: \_\_\_\_\_

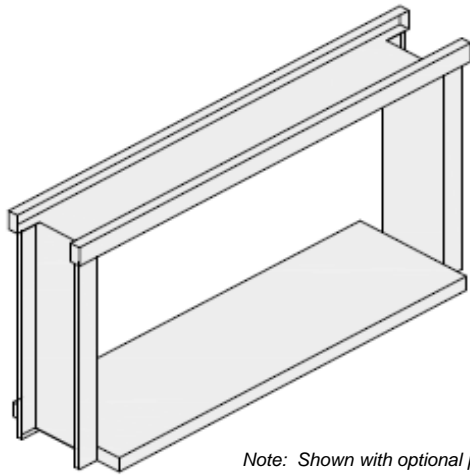

Note: Shown with optional port trim

### Material:

- 18 ga Type 304 stainless steel
- 1 1/2" turn down on sides
- Bottom pan with wood sub-ply

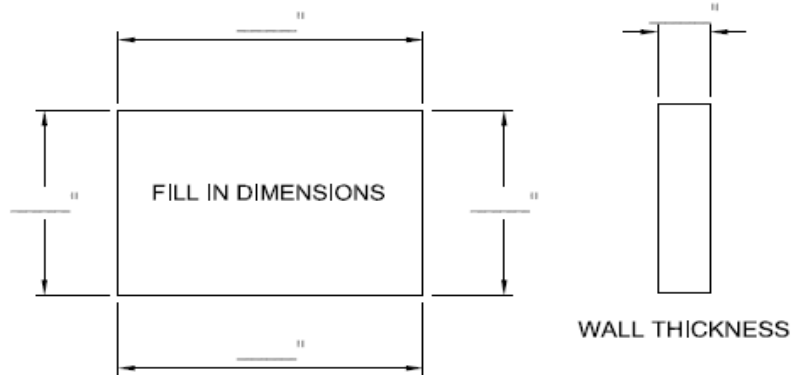
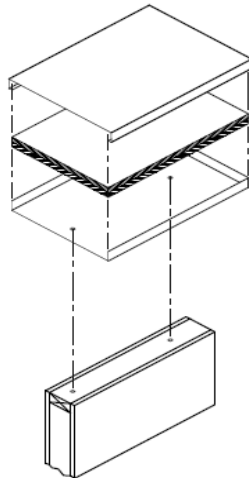

*\*\*If port trim option is selected, fill in dimensions above*

MODEL NUMBER	WIDTH	HEIGHT	WEIGHT (LBS.)
	A	B	
PS-4812	48"	12"	20
PS-6012	60"	12"	25
PS-7212	72"	12"	30
PS-8412	84"	12"	35
PS-9612	96"	12"	40
PS-10812	108"	12"	45
PS-12012	120"	12"	50
PS-13212	132"	12"	55
PS-14412	144"	12"	60
<b>CUSTOM</b>	<b>A</b>	<b>B</b>	

### Options/Accessories

- 16 ga stainless steel
- Port trim
- Rolled edges (2 long sides)
- Additional shelf - submittal dwgs req'd
- Heat lamp brackets
- Other \_\_\_\_\_

Item #: \_\_\_\_\_ Qty #: \_\_\_\_\_

Model #: \_\_\_\_\_

Project: \_\_\_\_\_

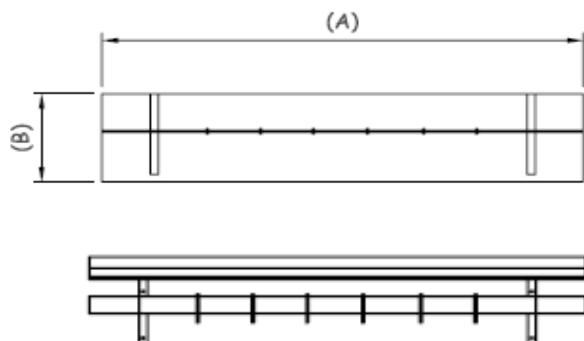

Note: Shelves in an excess of 84" will receive 3 brackets

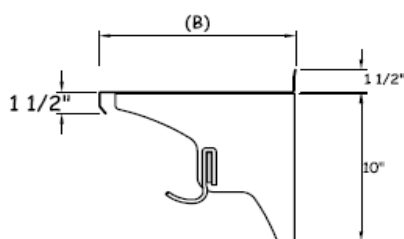

**Features:**

- Furnished with a 1 1/2" turn up at rear with 1 1/2" turn down front and sides
- Easy installation that includes 1 bracket every 36"

**Construction:**

- All shelves are fully welded and polished to a smooth grain finish.
- 304 stainless steel.
- Brackets are shipped loose.
- Flat bar pot rack with one pot hook every 12"

**Options:**

- Left end turn up
- Right end turn up
- 16 ga. Shelf / 14 ga. Brkts.
- Other \_\_\_\_\_



**Material:**

**Shelf:** 18 gauge type 304 series stainless steel

**Brackets:** 16 gauge stainless steel

**Custom Sizes Available!**

MODEL NUMBER	QTY	DIMENSIONS		WT. (lbs.)	MODEL NUMBER	QTY	DIMENSIONS		WT. (lbs.)	MODEL NUMBER	QTY	DIMENSIONS		WT. (lbs.)
		A	B				A	B				A	B	
WPP-36-12		36"	12"	27	WPP-72-14		72"	14"	57	WPP-108-16		108"	16"	91
WPP-36-14		36"	14"	30	WPP-72-16		72"	16"	62	WPP-108-18		108"	18"	99
WPP-36-16		36"	16"	32	WPP-72-18		72"	18"	67	WPP-120-12		120"	12"	84
WPP-36-18		36"	18"	35	WPP-84-12		84"	12"	60	WPP-120-14		120"	14"	93
WPP-48-12		48"	12"	36	WPP-84-14		84"	14"	66	WPP-120-16		120"	16"	101
WPP-48-14		48"	14"	39	WPP-84-16		84"	16"	72	WPP-120-18		120"	18"	109
WPP-48-16		48"	16"	43	WPP-84-18		84"	18"	78	WPP-132-12		132"	12"	99
WPP-48-18		48"	18"	46	WPP-96-12		96"	12"	68	WPP-132-14		132"	14"	108
WPP-60-12		60"	12"	44	WPP-96-14		96"	14"	75	WPP-132-16		132"	16"	117
WPP-60-14		60"	14"	48	WPP-96-16		96"	16"	81	WPP-132-18		132"	18"	127
WPP-60-16		60"	16"	52	WPP-96-18		96"	18"	88	WPP-144-12		144"	12"	108
WPP-60-18		60"	18"	57	WPP-108-12		108"	12"	76	WPP-144-14		144"	14"	118
WPP-72-12		72"	12"	52	WPP-108-14		108"	14"	84	WPP-144-16		144"	16"	128
<b>CUSTOM SHELF</b>		<b>DIM. A</b>		<b>DIM. B</b>	<b>QTY</b>	WPP-144-18		144'	18"	138				

WT. = Crated shipping weight



Item #: \_\_\_\_\_ Qty #: \_\_\_\_\_  
 Model #: \_\_\_\_\_  
 Project: \_\_\_\_\_

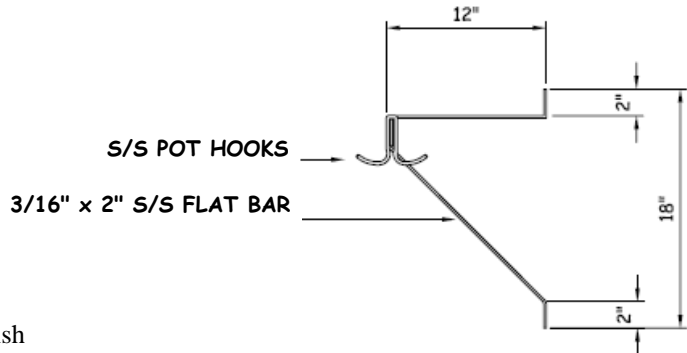
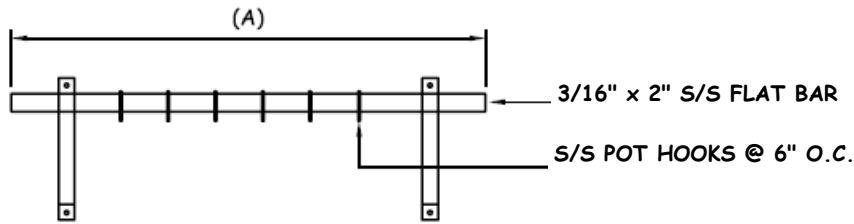

**Material:**

**Bar:** 3/16" x 2" Stainless Steel Flat Bar with Brushed Finish

**Brackets:** 1/8" stainless steel

**Pot Hooks:** Double Sided Stainless Steel - Supplied 1 every 12"

*Note: Models 84" and longer will be supplied with 3 support brackets*

MODEL NUMBER	LENGTH (A)	WT. (LBS.)	QTY
WMS-48	48"	16	
WMS-60	60"	19	
WMS-72	72"	22	
WMS-84	84"	25	
WMS-96	96"	28	
WMS-108	108"	31	
WMS-120	120"	34	
<b>CUSTOM</b>	<b>LENGTH</b>		<b>QTY</b>

**Premier Line Pot Racks**  
**Wall Mounted Double Pot Racks**

Item #: \_\_\_\_\_ Qty #: \_\_\_\_\_  
 Model #: \_\_\_\_\_  
 Project: \_\_\_\_\_

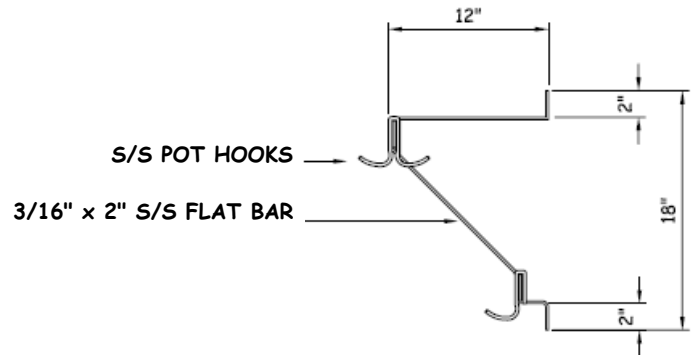
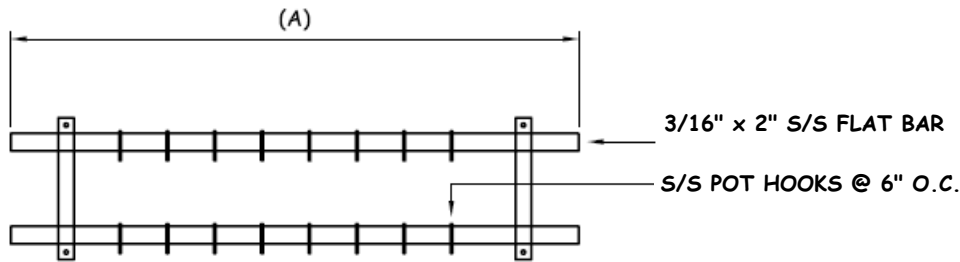

**Material:**

- Bars:** 3/16" x 2" Stainless Steel Flat Bar with Brushed Finish
- Brackets:** 1/8" stainless steel
- Pot Hooks:** Double Sided Stainless Steel - Supplied 1 every 12"

*Note: Models 84" and longer will be supplied with 3 support brackets*

MODEL NUMBER	LENGTH (A)	WT. (LBS.)	QTY
WMD-48	48"	16	
WMD-60	60"	19	
WMD-72	72"	22	
WMD-84	84"	25	
WMD-96	96"	28	
WMD-108	108"	31	
WMD-120	120"	34	
<b>CUSTOM</b>	<b>LENGTH</b>		<b>QTY</b>

**Premier Line Pot Racks**  
**Table Mounted Single Pot Racks**

Item #: \_\_\_\_\_ Qty #: \_\_\_\_\_  
 Model #: \_\_\_\_\_  
 Project: \_\_\_\_\_

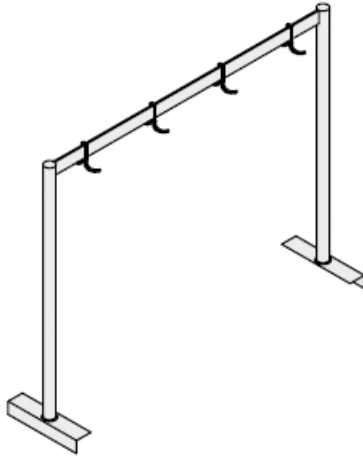

**Features:**

- Welded construction
- Shipped assembled
- Heavy duty
- Removable s/s pot hooks

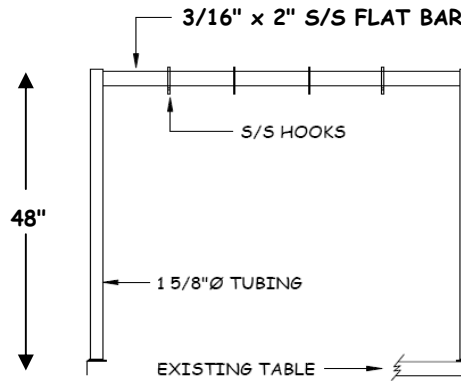

End View

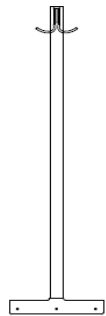

**Material:**

**Bar:** 3/16" x 2" Stainless Steel Flat Bar with Brushed Finish

**Legs:** 1 5/8" Stainless Steel

**Pot Hooks:** Double Sided Stainless Steel - Supplied 1 every 12"

**Options:**

- Height \_\_\_\_\_" from floor
- Factory mounted
- (circle one) middle rear
- Other \_\_\_\_\_

MODEL NUMBER	LENGTH (A)	WT. (LBS.)	QTY
TMS-48	48"	22	
TMS-60	60"	25	
TMS-72	72"	27	
TMS-84	84"	30	
TMS-96	96"	32	
TMS-108	108"	35	
TMS-120	120"	37	
<b>CUSTOM</b>	<b>LENGTH</b>		<b>QTY</b>

Note: Models 84" and longer will be supplied with 3 support brackets



## Premier Line Pot Racks

### Ceiling Mounted Pot Racks

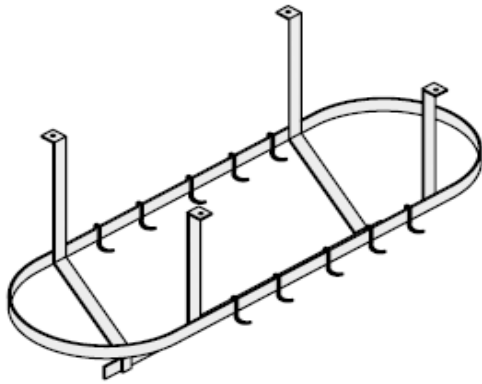

Item #: \_\_\_\_\_ Qty #: \_\_\_\_\_  
 Model #: \_\_\_\_\_  
 Project: \_\_\_\_\_

#### Features:

- Welded construction
- Shipped assembled
- Heavy duty
- Removable s/s pot hooks

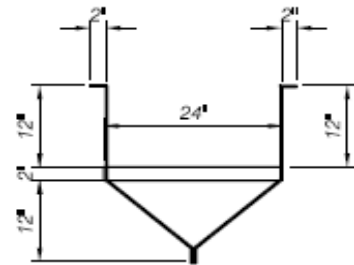
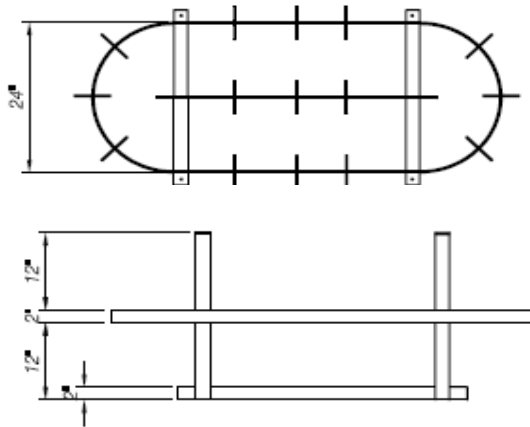

#### Material:

**Bar:** 3/16" x 2" Stainless Steel Flat Bar with Brushed Finish

**Pot Hooks:** Double Sided Stainless Steel - Supplied 1 every 12"

**\*\*\*PROVIDE CEILING HEIGHT FOR PROPER FIT\*\*\***

Ceiling height is \_\_\_\_\_

MODEL NUMBER	LENGTH (A)	WT. (LBS.)	QTY
CM-48	48"	70	
CM-60	60"	79	
CM-72	72"	88	
CM-84	84"	97	
CM-96	96"	106	
CM-108	108"	115	
CM-120	120"	124	
<b>CUSTOM</b>	<b>LENGTH</b>		<b>QTY</b>

# Standard Line Wall Shelves

## WSS-Wall Shelves

Item #: \_\_\_\_\_ Qty #: \_\_\_\_\_  
 Model #: \_\_\_\_\_  
 Project: \_\_\_\_\_

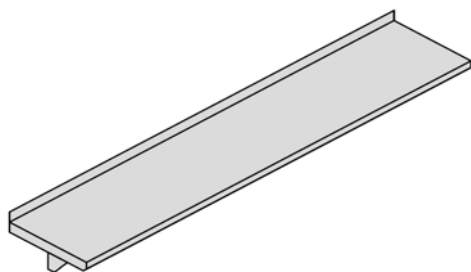

### Features:

- Furnished with a 1 1/2" turn up at rear with 1 1/2" turn down front and sides
- Easy installation that includes 1 bracket every 36"

### Construction:

- All shelves are fully welded and polished to a smooth grain finish
- "430" stainless steel
- Brackets are shipped loose

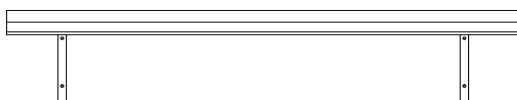

Note: Shelves in excess of 84" will receive 3 brackets

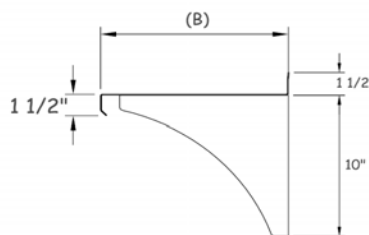
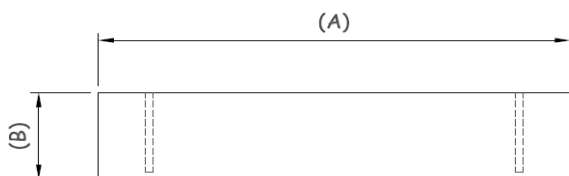

### Options:

- Left end turn up
- Right end turn up
- 16 ga. Shelf / 14 ga. Brkts.
- Other \_\_\_\_\_

### Material:

**Shelf:** 18 gauge stainless steel

**Brackets:** 16 gauge stainless steel

**Custom Sizes Available!**

MODEL NUMBER	QTY	DIMENSIONS		WT. (lbs.)	MODEL NUMBER	QTY	DIMENSIONS		WT. (lbs.)	MODEL NUMBER	QTY	DIMENSIONS		WT. (lbs.)
		A	B				A	B				A	B	
WSS-36-12		36"	12"	15	WSS-72-14		72"	14"	35	WSS-108-16		108"	16"	60
WSS-36-14		36"	14"	18	WSS-72-16		72"	16"	40	WSS-108-18		108"	18"	68
WSS-36-16		36"	16"	20	WSS-72-18		72"	18"	45	WSS-120-12		120"	12"	50
WSS-36-18		36"	18"	23	WSS-84-12		84"	12"	35	WSS-120-14		120"	14"	59
WSS-48-12		48"	12"	20	WSS-84-14		84"	14"	41	WSS-120-16		120"	16"	67
WSS-48-14		48"	14"	23	WSS-84-16		84"	16"	47	WSS-120-18		120"	18"	75
WSS-48-16		48"	16"	27	WSS-84-18		84"	18"	53	WSS-132-12		132"	14"	55
WSS-48-18		48"	18"	30	WSS-96-12		96"	12"	40	WSS-132-14		132"	16"	64
WSS-60-12		60"	12"	25	WSS-96-14		96"	14"	47	WSS-132-16		132"	16"	73
WSS-60-14		60"	14"	29	WSS-96-16		96"	16"	53	WSS-132-18		132"	18"	83
WSS-60-16		60"	16"	33	WSS-96-18		96"	18"	60	WSS-144-12		144"	12"	60
WSS-60-18		60"	18"	38	WSS-108-12		108"	12"	45	WSS-144-14		144"	14"	70
WSS-72-12		72"	12"	30	WSS-108-14		108"	14"	53	WSS-144-16		144"	16"	80
<b>CUSTOM SHELF</b>		<b>DIM. A</b>		<b>DIM. B</b>		<b>QTY</b>		WSS-144-18		144"	18"	90		

WT. = Crated shipping weight



# Standard Line

## TSS - Table Mounted Double Shelf

Item #: \_\_\_\_\_ Qty #: \_\_\_\_\_  
 Model #: \_\_\_\_\_  
 Project: \_\_\_\_\_

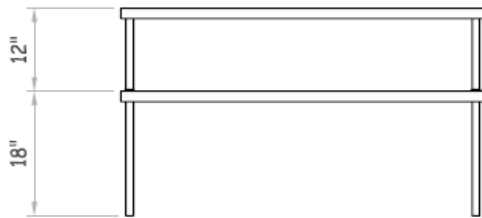
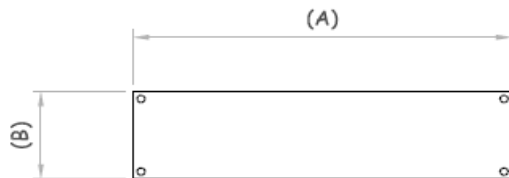
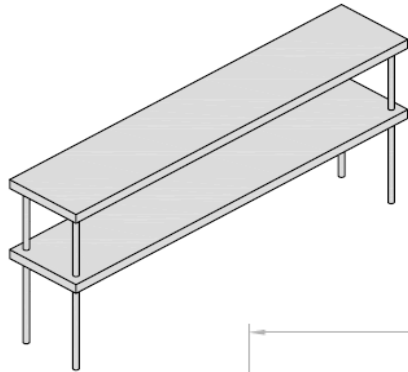

Models over 84" will receive 3 sets of legs

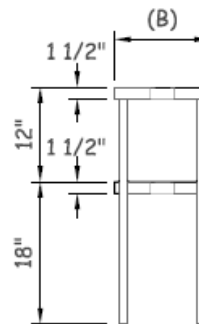

### Features:

- Furnished with 1" turn down on four sides.
- All shelves are fully welded and polished to a smooth grain finish.

### Construction:

- 1" stainless steel legs
- "430" stainless steel
- Galvanized support channels



### Options:

- 1 5/8" round posts
  - 1" turn up rear
  - 1" turn up left
  - 1" turn up right
  - Mounting brackets for existing table
  - Heat lamp brackets
  - Rolled edges on long sides
  - Hi-lited edges
  - Mounting location: (circle below)
- Front    Center    Rear
- Electrical boxes    QTY \_\_\_\_\_
  - Other: \_\_\_\_\_

### Material:

**Shelf:** 18 gauge stainless steel

**Legs:** 1" round stainless steel

### Custom Sizes Available!

MODEL NUMBER	DIMENSIONS		WT. (lbs.)	MODEL NUMBER	DIMENSIONS		WT. (lbs.)	MODEL NUMBER	DIMENSIONS		WT. (lbs.)	MODEL NUMBER	DIMENSIONS		WT. (lbs.)
	A	B			A	B			A	B			A	B	
TSS-2-36-10	36"	10"	26	TSS-2-60-16	60"	16"	68	TSS-2-96-10	96"	10"	68	TSS-2-120-16	120"	16"	134
TSS-2-36-12	36"	12"	30	TSS-2-60-18	60"	18"	76	TSS-2-96-12	96"	12"	80	TSS-2-120-18	120"	18"	150
TSS-2-36-14	36"	14"	38	TSS-2-60-20	60"	20"	84	TSS-2-96-14	96"	14"	94	TSS-2-120-20	120"	20"	168
TSS-2-36-16	36"	16"	40	TSS-2-72-10	72"	10"	50	TSS-2-96-16	96"	16"	108	TSS-2-132-10	132"	10"	92
TSS-2-36-18	36"	18"	46	TSS-2-72-12	72"	12"	60	TSS-2-96-18	96"	18"	120	TSS-2-132-12	132"	12"	110
TSS-2-36-20	36"	20"	50	TSS-2-72-14	72"	14"	70	TSS-2-96-20	96"	20"	134	TSS-2-132-14	132"	14"	130
TSS-2-48-10	48"	10"	32	TSS-2-72-16	72"	16"	80	TSS-2-108-10	108"	10"	76	TSS-2-132-16	132"	16"	146
TSS-2-48-12	48"	12"	40	TSS-2-72-18	72"	18"	90	TSS-2-108-12	108"	12"	90	TSS-2-132-18	132"	18"	166
TSS-2-48-14	48"	14"	48	TSS-2-72-20	72"	20"	100	TSS-2-108-14	108"	14"	106	TSS-2-132-20	132"	20"	184
TSS-2-48-16	48"	16"	54	TSS-2-84-10	84"	10"	60	TSS-2-108-16	108"	16"	120	TSS-2-144-10	144"	10"	100
TSS-2-48-18	48"	18"	60	TSS-2-84-12	84"	12"	70	TSS-2-108-18	108"	18"	136	TSS-2-144-12	144"	12"	120
TSS-2-48-20	48"	20"	68	TSS-2-84-14	84"	14"	82	TSS-2-108-20	108"	20"	150	TSS-2-144-14	144"	14"	140
TSS-2-60-10	60"	10"	42	TSS-2-84-16	84"	16"	94	TSS-2-120-10	120"	10"	84	TSS-2-144-16	144"	16"	160
TSS-2-60-12	60"	12"	50	TSS-2-84-18	84"	18"	106	TSS-2-120-12	120"	12"	100	TSS-2-144-18	144"	18"	180
TSS-2-60-14	60"	14"	58	TSS-2-84-20	84"	20"	118	TSS-2-120-14	120"	14"	116	TSS-2-144-20	144"	20"	200
									<b>CUSTOM</b>		<b>Dim. A</b>		<b>Dim. B</b>		

WT. = Crated shipping weight

## Standard Line Wall Shelf / Pot Rack Combo

Item #: \_\_\_\_\_ Qty #: \_\_\_\_\_  
 Model #: \_\_\_\_\_  
 Project: \_\_\_\_\_

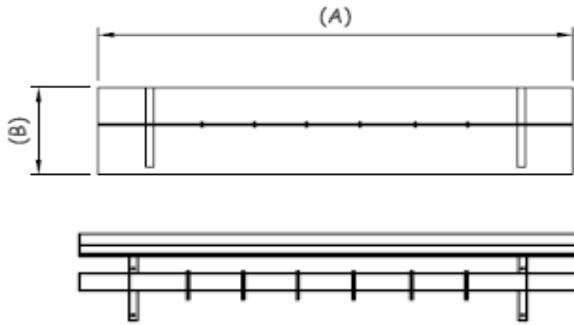

### Features:

- Furnished with a 1 1/2" turn up at rear with 1 1/2" turn down front and sides
- Easy installation that includes 1 bracket every 36"

### Construction:

- All shelves are fully welded and polished to a smooth grain finish.
- 430 stainless steel
- Brackets are shipped loose.
- Flat bar pot rack with one pot hook every 12"



Note: Shelves in an excess of 84" will receive 3 brackets

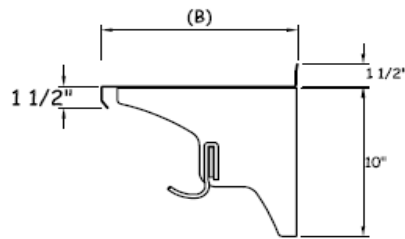

**Options:**

Left end turn up  
 Right end turn up  
 16 ga. Shelf / 14 ga. Brkts.  
 Other \_\_\_\_\_

### Material:

**Shelf:** 18 gauge stainless steel

**Brackets:** 16 gauge stainless steel

**Custom Sizes Available!**

MODEL NUMBER	QTY	DIMENSIONS		WT. (lbs.)	MODEL NUMBER	QTY	DIMENSIONS		WT. (lbs.)	MODEL NUMBER	QTY	DIMENSIONS		WT. (lbs.)
		A	B				A	B				A	B	
WSPP-36-12		36"	12"	27	WSPP-72-14		72"	14"	57	WSPP-108-16		108"	16"	91
WSPP-36-14		36"	14"	30	WSPP-72-16		72"	16"	62	WSPP-108-18		108"	18"	99
WSPP-36-16		36"	16"	32	WSPP-72-18		72"	18"	67	WSPP-120-12		120"	12"	84
WSPP-36-18		36"	18"	35	WSPP-84-12		84"	12"	60	WSPP-120-14		120"	14"	93
WSPP-48-12		48"	12"	36	WSPP-84-14		84"	14"	66	WSPP-120-16		120"	16"	101
WSPP-48-14		48"	14"	39	WSPP-84-16		84"	16"	72	WSPP-120-18		120"	18"	109
WSPP-48-16		48"	16"	43	WSPP-84-18		84"	18"	78	WSPP-132-12		132"	14"	99
WSPP-48-18		48"	18"	46	WSPP-96-12		96"	12"	68	WSPP-132-14		132"	16"	108
WSPP-60-12		60"	12"	44	WSPP-96-14		96"	14"	75	WSPP-132-16		132"	16"	117
WSPP-60-14		60"	14"	48	WSPP-96-16		96"	16"	81	WSPP-132-18		132"	18"	127
WSPP-60-16		60"	16"	52	WSPP-96-18		96"	18"	88	WSPP-144-12		144"	12"	108
WSPP-60-18		60"	18"	57	WSPP-108-12		108"	12"	76	WSPP-144-14		144"	14"	118
WSPP-72-12		72"	12"	52	WSPP-108-14		108"	14"	84	WSPP-144-16		144"	16"	128
<b>CUSTOM SHELF</b>		<b>DIM. A</b>		<b>DIM. B</b>		<b>QTY</b>				<b>WSPP-144-18</b>				

WT. = Crated shipping weight



## Standard Line Shelves Microwave Shelves

Item #: \_\_\_\_\_ Qty #: \_\_\_\_\_  
Model #: \_\_\_\_\_  
Project: \_\_\_\_\_

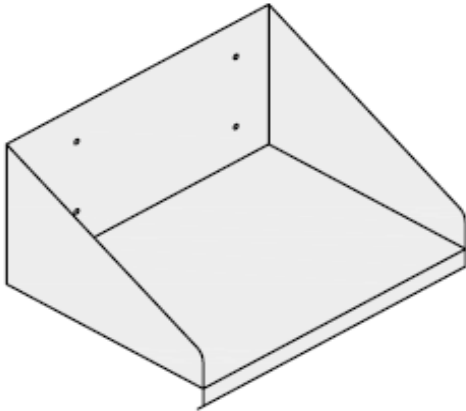

### Features:

- Furnished with a 12" turn up at rear with 12" tapered turn up at sides
- Easy installation with no brackets

### Construction:

- All shelves are fully welded and polished to a smooth grain finish.
- 430 stainless steel
- 1 1/2" turn down in front



MODEL NUMBER	DIMENSIONS		WT (lbs)
	A	B	
MWS-2418	24"	18"	15
MWS-2424	24"	24"	20
<i>Custom</i>	<i>A</i>	<i>B</i>	

### Material:

Shelf: 18 gauge stainless steel

### Custom Sizes Available!

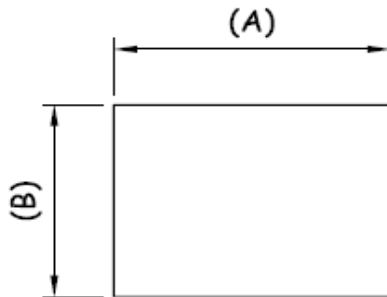

- Options:**
- 16 ga. S/S
  - 304 series S/S
  - Grommet hole for cord

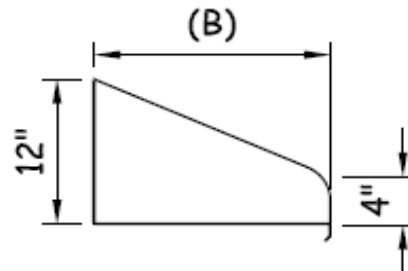
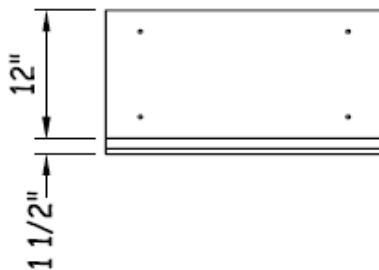



## Standard Line Shelves Dishtable Sorting Shelves

Item #: \_\_\_\_\_ Qty #: \_\_\_\_\_

Model #: \_\_\_\_\_

Project: \_\_\_\_\_

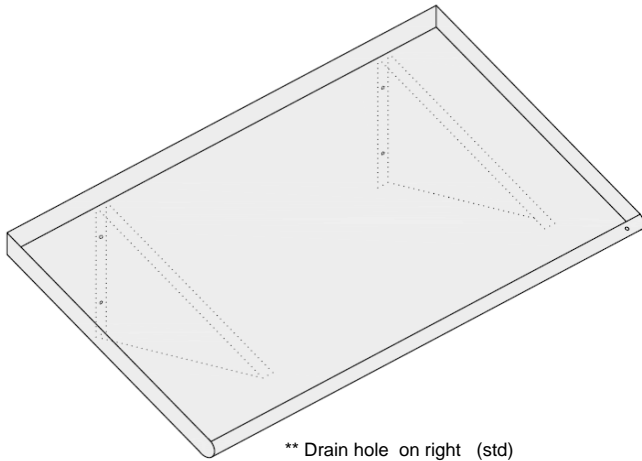

\*\* Drain hole on right (std)

### Features:

- Furnished with a 1 1/2" turn up at rear and sides and 1 1/2" roll on front edge.
- Easy installation that includes 2 brackets (shipped loose)

### Construction:

- All shelves are fully welded and polished to a smooth grain finish.
- Drain hole on right side (std.)



### Material:

**Shelf:** 18 gauge type "304" series stainless steel

**Brackets:** 16 gauge type "304" series stainless steel

MODEL NUMBER	DIMENSIONS		WT (lbs)
	A	B	
SWS-1	21"	21"	20
SWS-2	42"	21"	35
SWS-3	63"	21"	50
<i>Custom</i>	<i>A</i>	<i>B</i>	

### Custom Sizes Available!

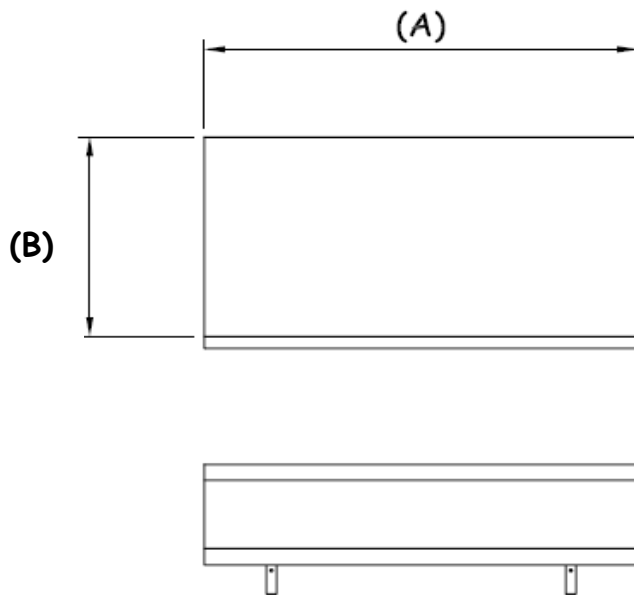

### Options:

- 16 ga. shelf
- 14 ga. S/S brackets
- Drip hole on left

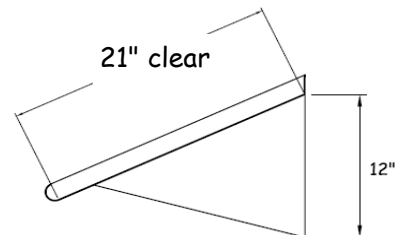

[www.weststarindustries.com](http://www.weststarindustries.com)

4445 E. Fremont Street / Stockton, CA 95215

Phone: 800-326-2288 Fax: (209) 955-8250 CL# 422322

Email: [wsi@weststarindustries.com](mailto:wsi@weststarindustries.com)

Note: Specifications are subject to change without notice.



## Standard Line Shelves Dishtable Sorting Shelves

Item #: \_\_\_\_\_ Qty #: \_\_\_\_\_

Model #: \_\_\_\_\_

Project: \_\_\_\_\_

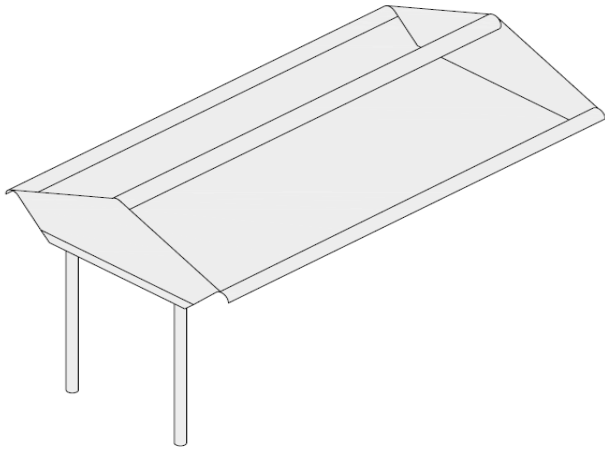

### Features:

- Fully welded for extra strength and durability
- Easy to clean

### Construction:

- All shelves are fully welded and polished to a smooth grain finish.
- One end mounts to wall and other end mounts to dishtable edge



### Material:

**Shelf:** 18 gauge type "304" series stainless steel

**Legs:** 1" round 16 gauge stainless steel

MODEL NUMBER	DIMENSIONS		WT (lbs)
	A	Width	
DRS-48	48"	25 1/2"	50
DRS-60	60"	25 1/2"	62
DRS-72	72"	25 1/2"	75
DRS-84	84"	25 1/2"	87
DRS-96	96"	25 1/2"	100
<b>CUSTOM</b>	<b>A</b>	<b>B</b>	

### Custom Sizes Available!

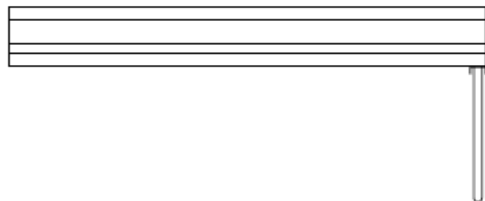
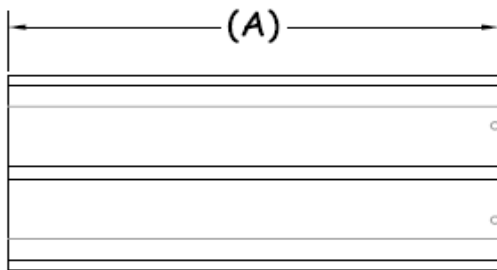

### Options:

- 16 ga. S/S
- 1 5/8" legs

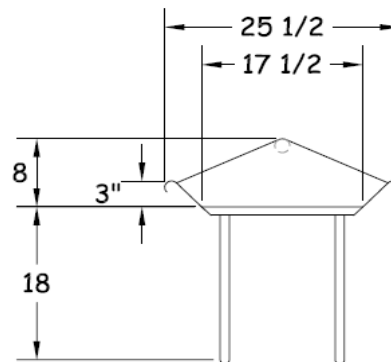

\*\*Any length longer than 84" will have a center support

[www.weststarindustries.com](http://www.weststarindustries.com)

4445 E. Fremont Street / Stockton, CA 95215

Phone: 800-326-2288 Fax: (209) 955-8250 CL# 422322

Email: [wsj@weststarindustries.com](mailto:wsj@weststarindustries.com)

Note: Specifications are subject to change without notice.